

MINIATURE CERAMIC SMD CRYSTAL



ABM3

5.0 X 3.2 X 1.30mm

ABM3

*G = Pb in glass (exempt per RoHS 2002/95/EC Annex (5))

RoHS
Compliant

OUTLINE DRAWING:

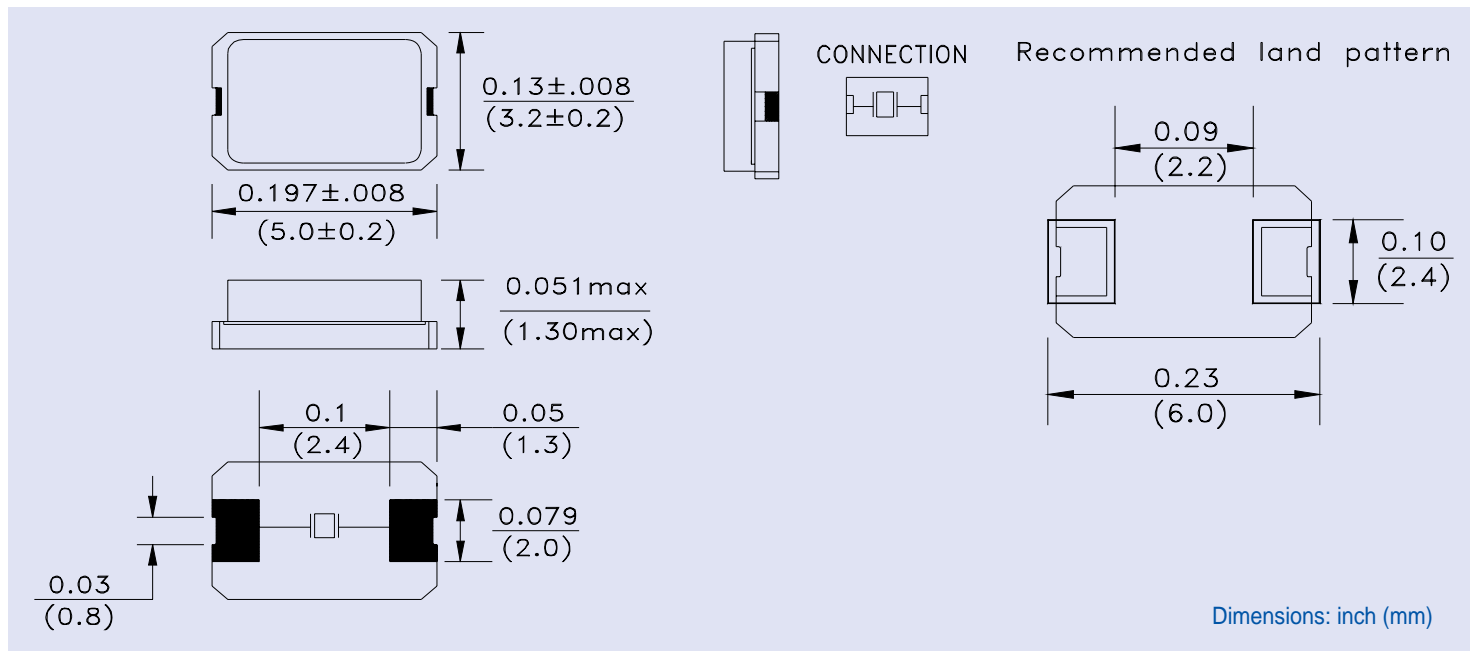

TAPE & REEL:

