

# 869MHz SMD SAW FILTER

AFS869.0W01-TS4



RoHS  
Compliant



3.0 x 3.0 x .85mm

## FEATURES:

- Low loss
- 3.0 x 3.0 x 1.5mm package
- Wide band

## APPLICATIONS:

- RF filter for telecommunications
- Wireless audio

## STANDARD SPECIFICATIONS:

### MAXIMUM RATINGS

Item	Value
Operation Temperature Range	-30°C to +80°C
Storage Temperature Range	-40°C to +85°C
DC Permissive Voltage	10V DC max.
Maximum Input Power	0 dBm

### ELECTRICAL CHARACTERISTICS

Item	Frequency (MHz)	Specification
Center Frequency (fo)	869.0	
3dB Band Width	8	
Insertion Loss	868.0 ~870.0	4.5 dB max.
Ripple	868.05 ~870.0	1.5 dB max
Relative Attenuation	825.0 ~ 828.0	40 dB min.
	846.0 ~ 849.0	35 dB min.
	889.0 ~ 892.0	35 dB min.
	910.0 ~ 913.0	40 dB min.
Input Impedance		50Ω
Output Impedance		50Ω

## TEST CIRCUIT

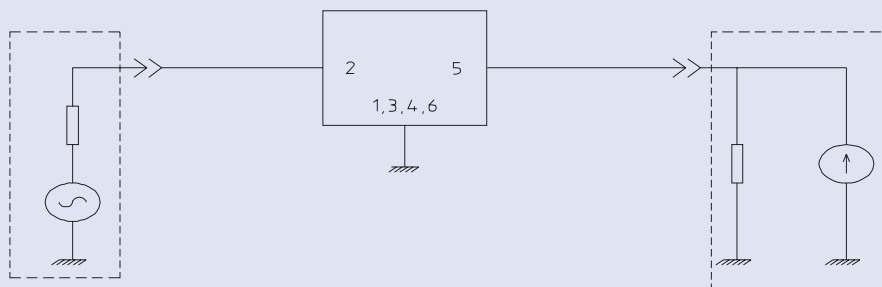

# 869MHz SMD SAW FILTER

AFS869.0W01-TS4



**RoHS**  
Compliant



3.0 x 3.0 x .85mm

## FREQUENCY CHARACTERISTICS

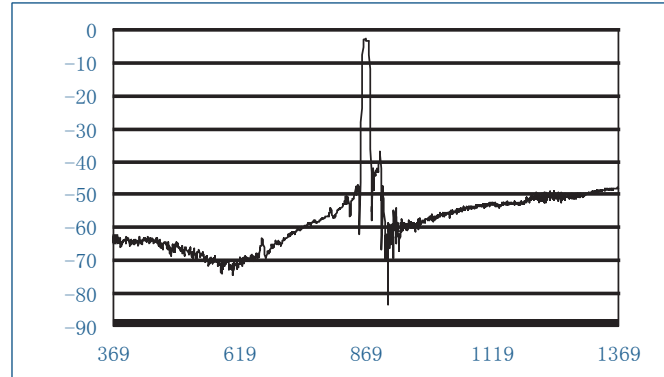
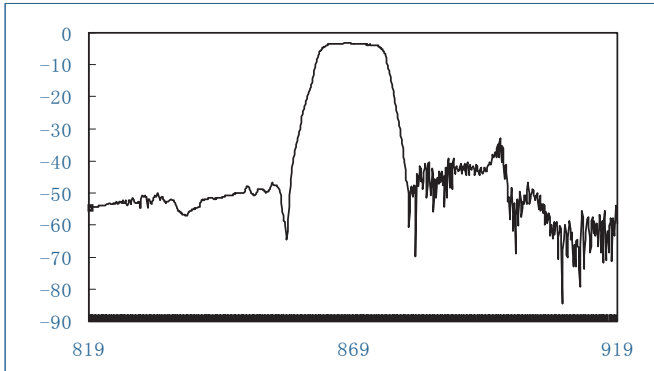

## OUTLINE DIMENSIONS:

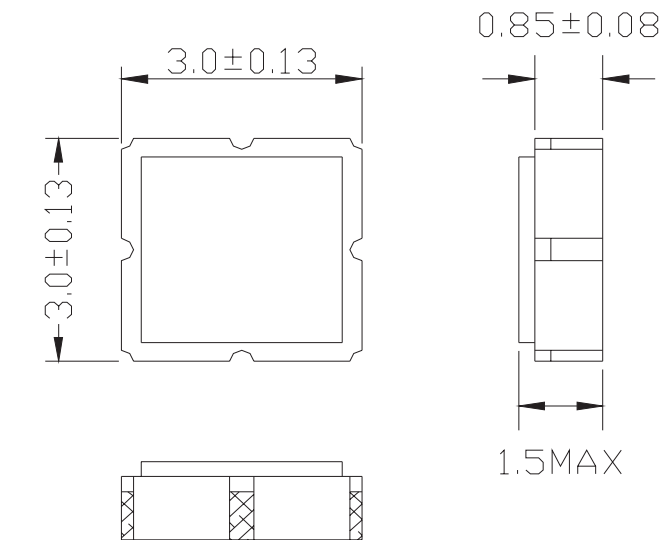

Dimension : mm

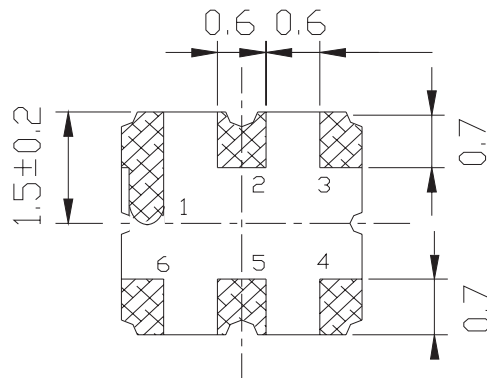

Pin No.	Function
Pin 1	Input
Pin 4	Output
Pin 2, 3	Ground

# 869MHz SMD SAW FILTER

AFS869.0W01-TS4



RoHS  
Compliant



3.0 x 3.0 x .85mm

## TAPE AND REEL:

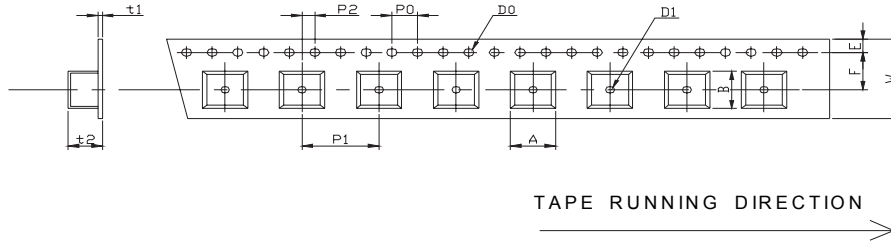

W	F	E	P0	P1	P2	D0	D1	t1	t2	A	B
12.0	5.5	1.75	4.0	4.0	2.0	Φ1.5	Φ1.5	0.31	1.70	3.3	3.3
±0.3	±0.1	±0.1	±0.2	±0.1	±0.2	±0.1	±0.25	max.	max.	max.	max.

Dimension : mm

## REFLOW PROFILE:

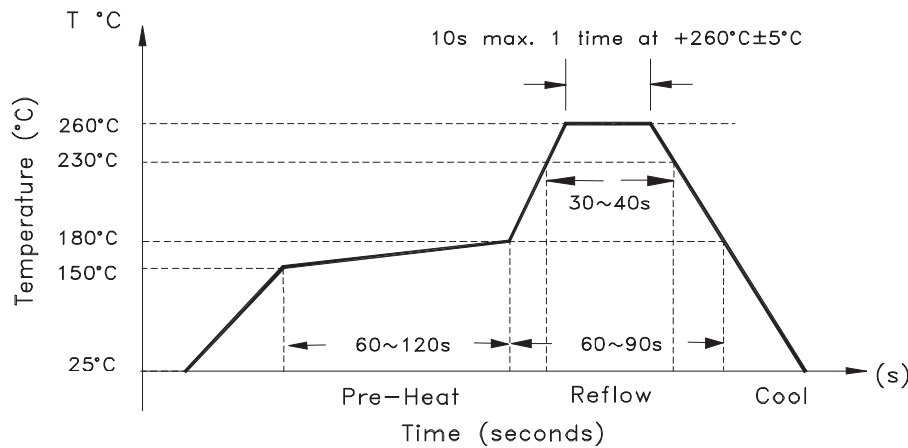

**NOTE:** Abracon manufactured products are intended for general commercial and industrial use. For applications requiring high reliability and/or presenting extreme operating environment, written consent & authorization from Abracon is required.

ABRACON IS  
ISO 9001 / QS 9000  
CERTIFIED



Visit [www.abracon.com](http://www.abracon.com) for Terms & Conditions of Sale **Revised: 08.13.09**  
30332 Esperanza, Rancho Santa Margarita, California 92688  
tel 949-546-8000 | fax 949-546-8001 | [www.abracon.com](http://www.abracon.com)